HA13561F

Combo (Spindle & VCM) Driver

HITACHI

ADE-207-182 (Z)
1st Edition
July 1996

Description

This COMBO Driver for HDD application consists of Sensorless Spindle Driver and BTL type VCM Driver.

Bipolar Process is applied and a “Soft Switching Circuit” for less commutation noise and a “Booster Circuit” for smaller Saturation Voltage of Output Transistor are also implemented.

Features

- Soft Switching Driver
Small Surface Mount Package: FP-80E (QFP80 Pin)
Low thermal resistance: 35°C/W with 6 layer multi glass-epoxy board
- Low output saturation voltage
 - Spindle 0.8 V Typ (@1.0 A)
 - VCM 0.8 V Typ (@0.8 A)

Functions

- 1.8 A Max/3-phase motor driver
- 1.2 A Max BTL VCM Driver
- Auto retract
- Soft Switching Matrix
- Start up circuit
- Booster
- Speed Discriminator
- Internal Protector (OTSD, LVI)
- POR
- Power monitor

Pin Arrangement

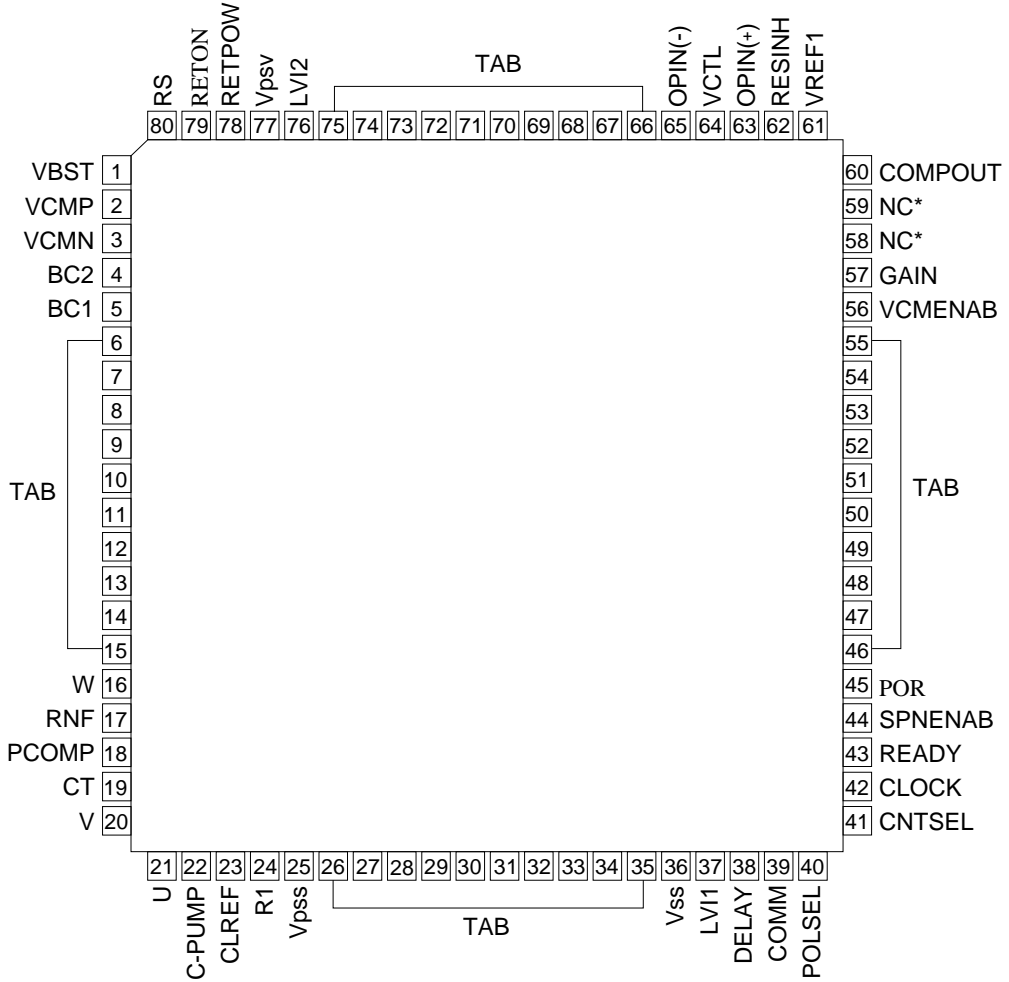

*NC : No internal connection

Please note that there is no isolation check between pin 58 and pin 59 at the testing of this IC.

(Top View)

Pin Description

Pin Number	Pin Name	Function
1	VBST	Boosted voltage output to realize the low output saturation voltage
2	VCMP	Output terminal on VCM driver
3	VCMN	Output terminal on VCM driver
4	BC2	To be attached the external capacitor for booster circuitry
5	BC1	ditto
6 to 15	GND	Ground pins
16	W	W phase output terminal on spindle motor driver
17	RNF	Sensing input for output current on spindle motor driver
18	PCOMP	To be attached the external capacitor for phase compensation of spindle motor driver
19	CT	To be attached the center tap of the spindle motor for B-EMF sensing
20	V	V phase output terminal on spindle motor driver
21	U	U phase output terminal on spindle motor driver
22	C-PUMP	To be attached the external integral constants for speed control of spindle motor
23	CLREF	Reference voltage input for current limiter of spindle motor driver
24	R1	To be attached the external resistor for setting up the oscillation frequency of start-up circuitry and the gain of speed control loop of spindle motor driver
25	V _{ps}	Power supply for spindle motor driver
26 to 35	GND	Ground pins
36	V _{ss}	Power supply for small signal block
37	LVI1	Sensing input for power monitor circuitry
38	DELAY	To be attached the external capacitor to generate the delay time for power on reset signal
39	COMM	To be attached the external capacitor for setting up the oscillation frequency
40	POLSEL	To be selected the input status corresponding to the pole number of spindle motor
41	CNTSEL	To select the count Number of Speed Discriminator
42	CLOCK	Master clock input for this IC
43	READY	Output of speed lock detector for spindle motor
44	SPENAB	To select the status of spindle motor driver
45	$\overline{\text{POR}}$	Output of power on reset signal for HDD system
46 to 55	GND	Ground pins
56	VCMENAB	To select the status of VCM driver
57	GAIN	To select the Transfer conductance gm of VCM driver

Pin Description (cont)

Pin Number	Pin Name	Function
58	NC	No function
59	NC	ditto
60	COMPOUT	Comparator output to detect the direction of output current on VCM driver
61	VREF1	Regulated voltage output to be used as reference of peripheral ICs
62	RESINH	Used for inhibiting the restart function of the spindle motor driver after power down
63	OPIN (+)	Non inverted input of OP.Amp. to be used for filtering the signal on PWMOUT
64	VCTL	OP. Amp. output, this signal is used as control signal for VCM driver output
65	OPIN (-)	Inverted input of OP.Amp. to be used for filtering the signal on PWMOUT
66 to 75	GND	Ground pins
76	LVI2	Sensing input for power monitor circuitry
77	Vpsv	Power supply for VCM driver
78	RETPOW	Power supply for retract circuitry
79	RETON	To be attached the base terminal of external transistor for retracting
80	RS	Sensing input for output current on VCM driver

Block Diagram

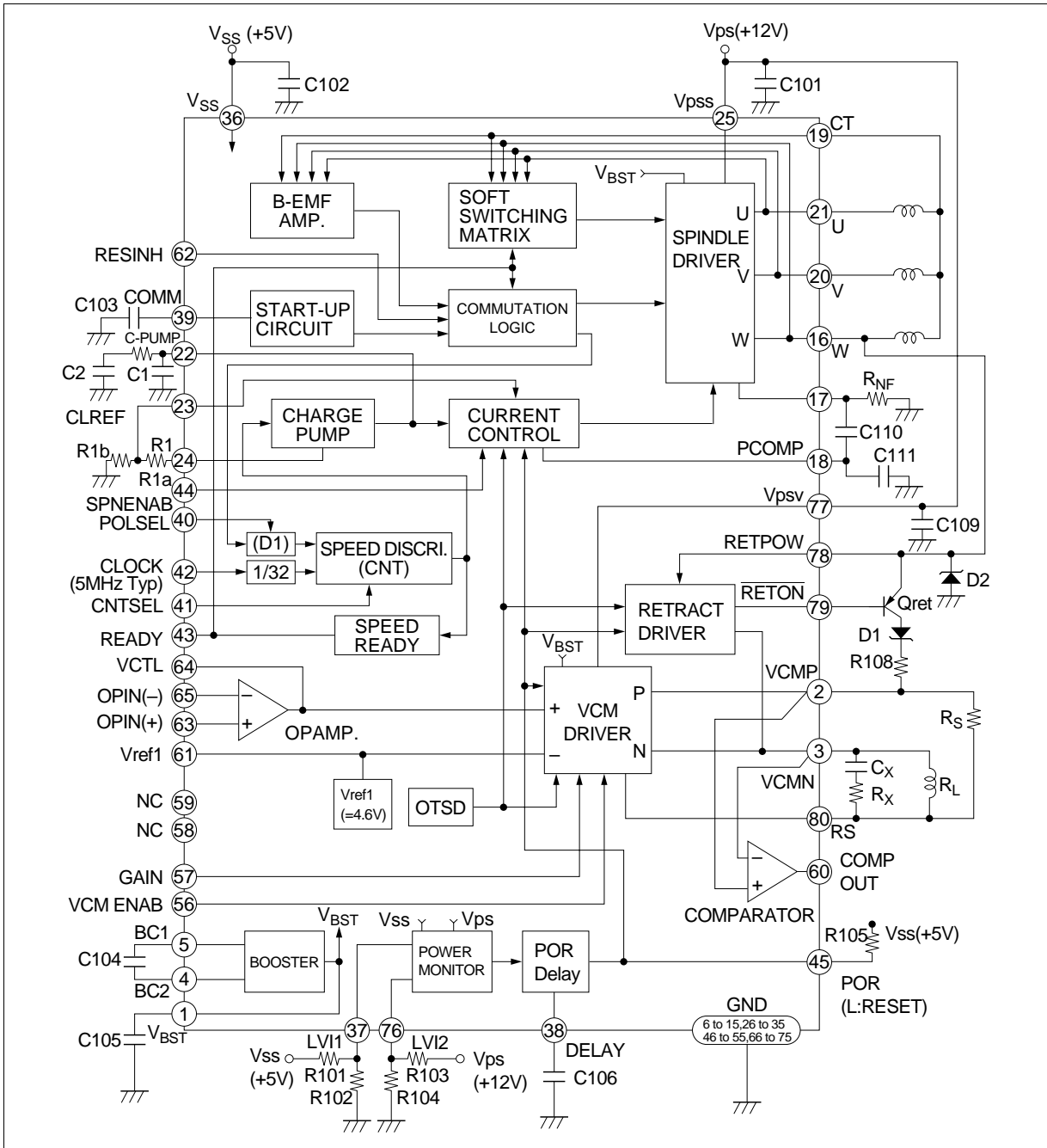

Truth Table**Table 1 Truth Table (1)**

SPNENAB	Spindle Driver
H	ON
Open	Cut off
L	Braking

Table 2 Truth Table (2)

VCMENAB	VCM Driver
H	ON
L	Cut off

Table 3 Truth Table (3)

OTSD	Spindle Driver	VCM Driver	Retract Driver
not Active	See table 1	See table 2	Cut off
Active	Cut off	Cut off	ON

Table 4 Truth Table (4)

POLSEL	(D1)	Comment
H	—	Test Mode
Open	1/12	for 8 poles motor
L	1/18	for 12 poles motor

Table 5 Truth Table (5)

CNTSEL	CNT	Rotation Speed (at CLOCK = 5 MHz)
H	2605	3,600 rpm
Open	2084	4,500 rpm
L	1736	5,400 rpm

Table 6 Truth Table (6)

RESINH	Spindle Driver
H	Inhibiting the restart after power down
L	Not inhibiting the restart after power down

Table 7 Truth Table (7)

GAIN	VCM Driver
H	High Gain Mode
L	Low Gain Mode

Timing Chart

1. Power on reset (1)

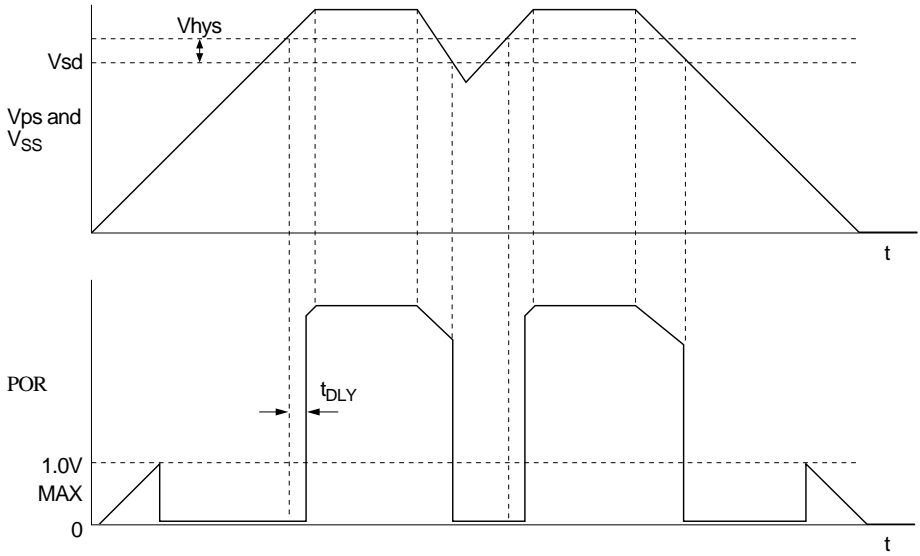

Note: 1. How to determine the threshold Voltage V_{sd} and the delay time t_{DLY} both are shown in the external components table.

2. Power on reset (2)

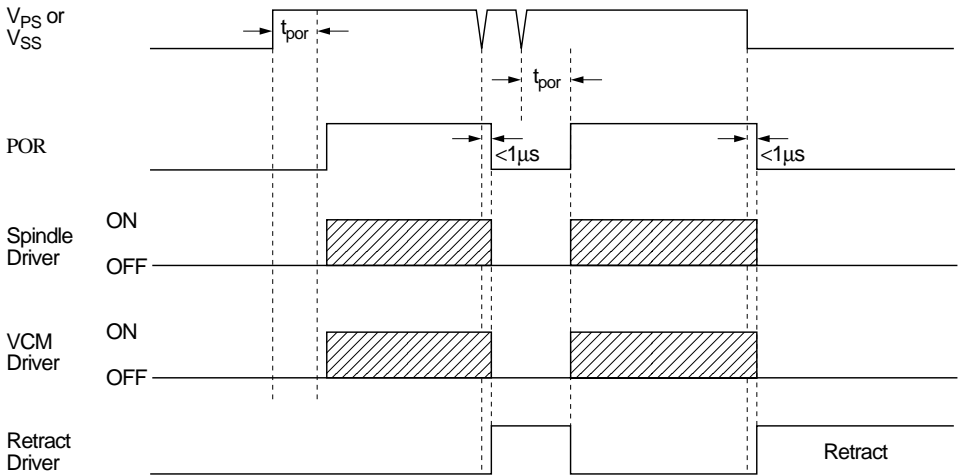

Note: 2. Retract driver need B-EMF voltage or another power supply.

3. Motor start-up sequence

(a) Timing chart of start-up sequence

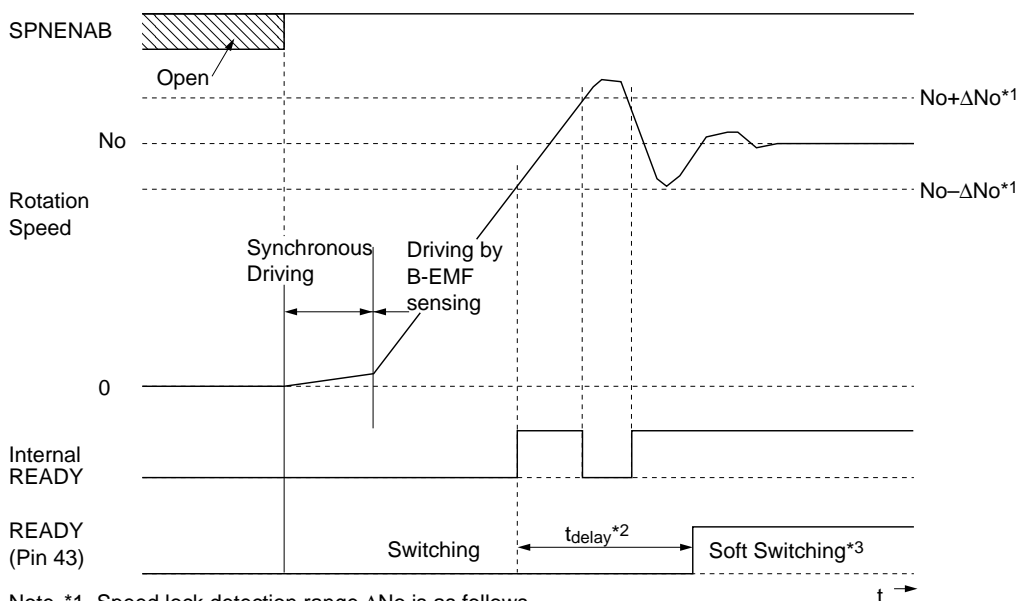

Note *1. Speed lock detection range ΔNo is as follows.

- $\Delta No = 1.2\%$ when CNTSEL=H
- $= 1.5\%$ when CNTSEL=Open
- $= 1.8\%$ when CNTSEL=L

*2. READY output goes to High, if the rotation speed error keeps to be less than ΔNo longer time than t_{delay} .

$$t_{delay} = \frac{500 \cdot 10^7}{f_{clk} [Hz]} \text{ [ms]}$$

*3. The turning point of driving mode from switching synchronize to the turning point of READY output from Low to High.

(b) Retry circuitry for misstart-up

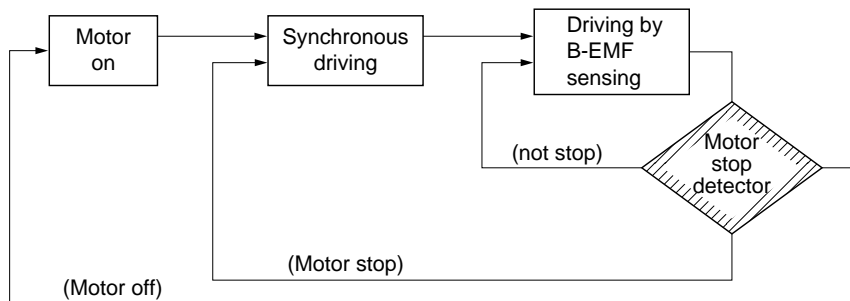

The HA13561F has the motor stop detector as shown hatching block. This function is monitoring the situation of the motor while the motor is running by B-EMF sensing. If the motor will be caused a misstarting up, the motor will be automatically restarted within 200 ms after the motor stopped. This function increase the reliability for the motor starting up.

4. Braking & Shut down the Spindle Driver

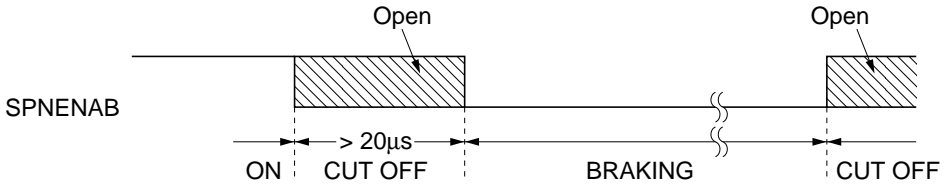

Note: The SPENAB should be selected the open state after braking to reduce the supply current from V_{ps} and V_{SS} .

5. Start-up of the Spindle motor

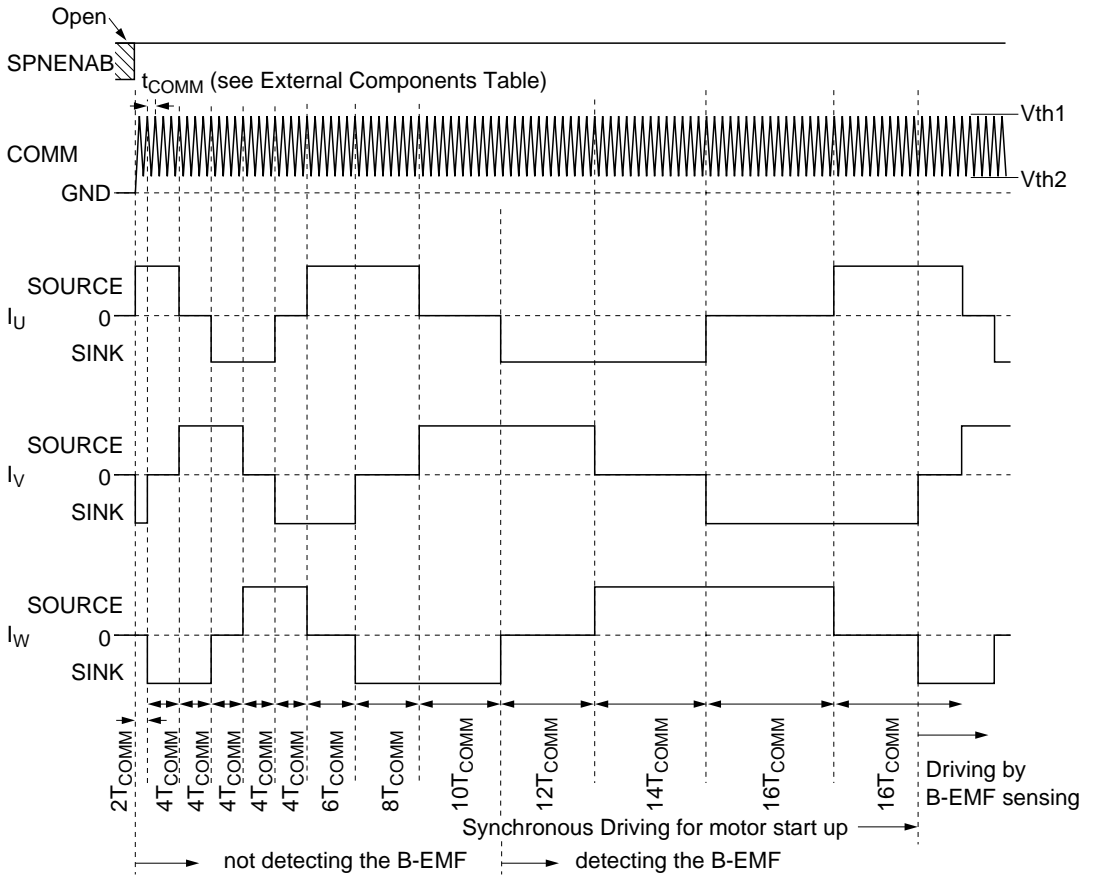

6. Acceleration and Running the spindle motor

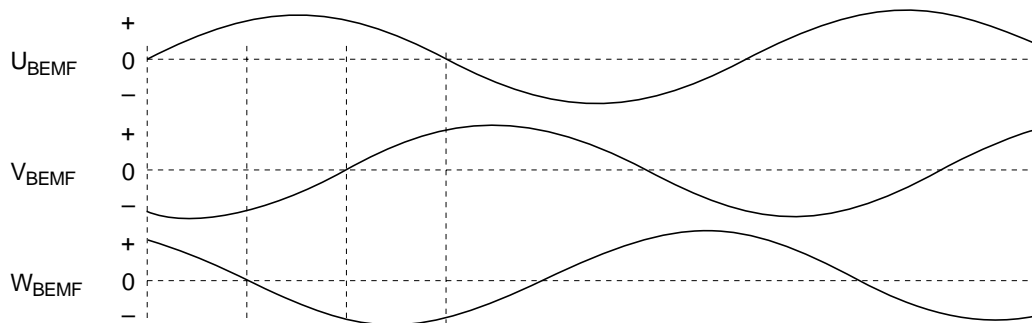

(1) Acceleration (switching mode)

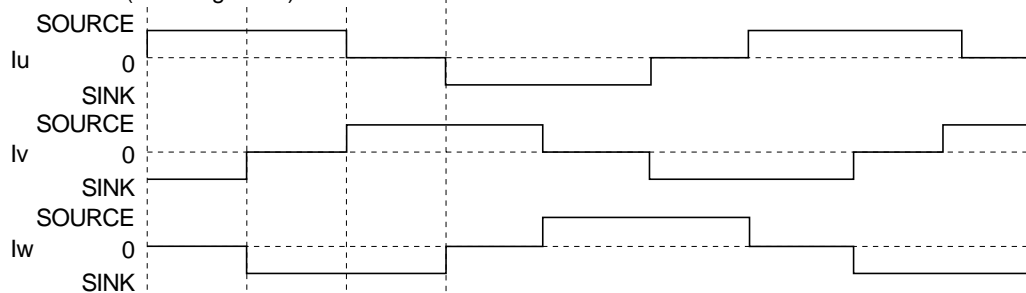

(2) Running (soft switching mode)

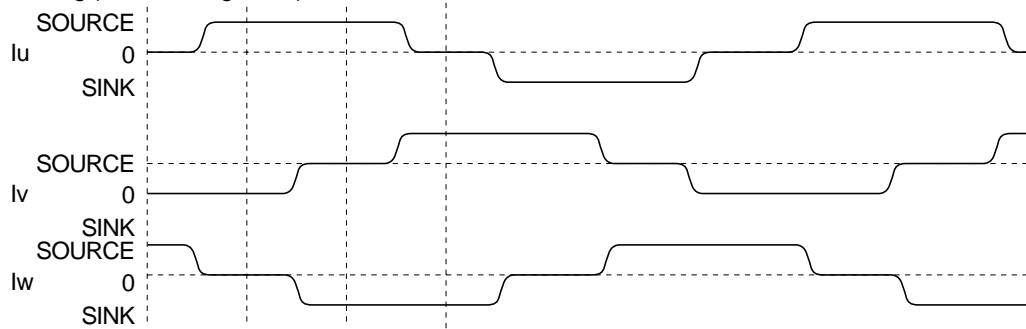

Application

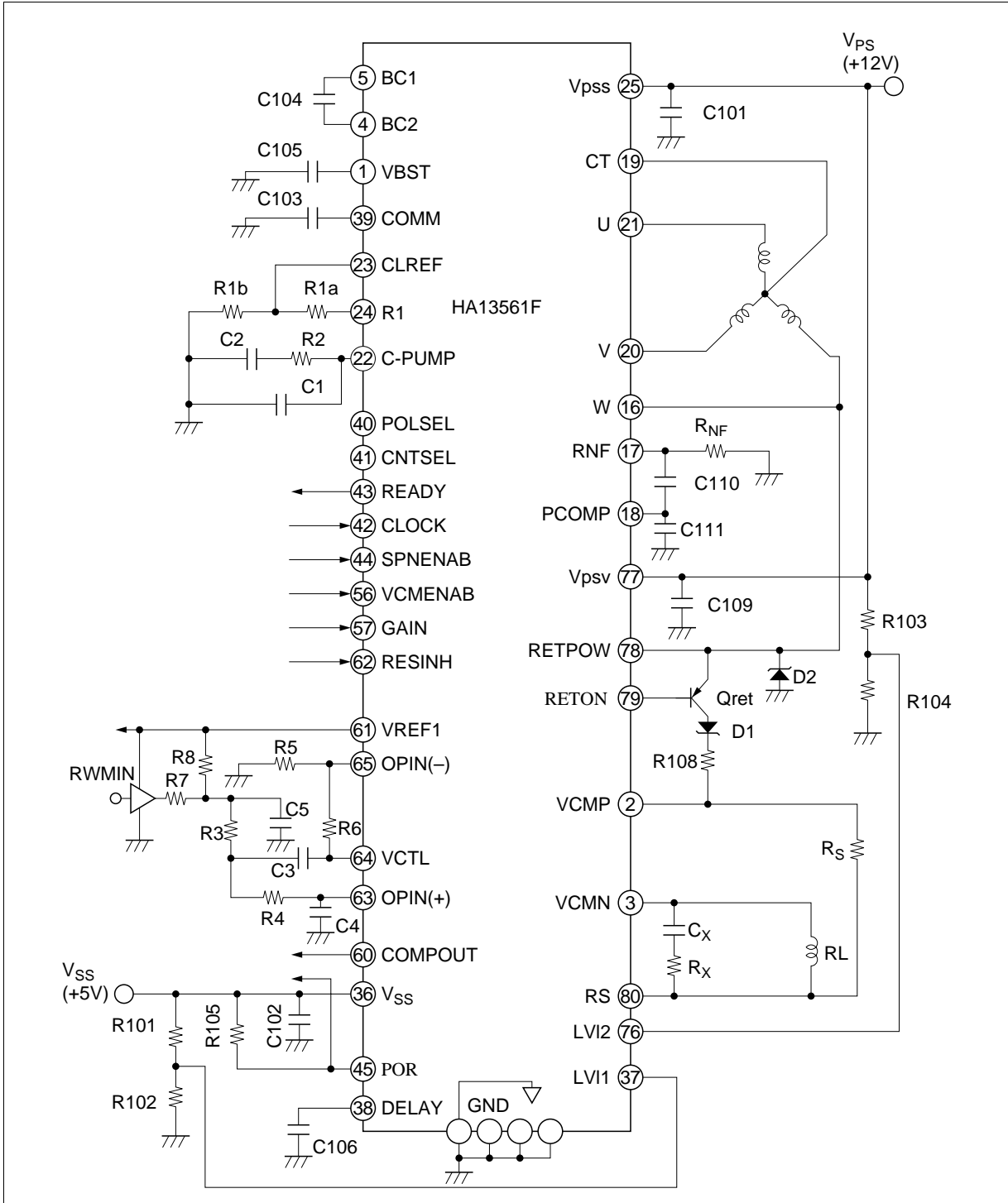

External Components

Parts No.	Recommended Value	Purpose	Note
R1a	(R1a + R1b) ≥ 10 kΩ	V/I converter	1, 4, 6
R1b	(R1a + R1b) ≥ 10 kΩ		
R2	—	Integral constant	3
R3 to R8	—	PWM filter	9
R101, R102	—	Setting of LVI1 voltage	7
R103, R104	—	Setting of LVI2 voltage	7
R105	5.6 kΩ	Pull up	
R108	—	Limitation for Retract current	12
RS	1.0 Ω	Current sensing for VCM Driver	10
Rnf	—	Current sensing for Spindle Driver	1
R _x	—	Reduction for gain peaking	11
C1, C2	—	Integral constant	3
C3 to C6	—	PWM filter	9
C _x	—	Reduction for gain peaking	11
C101	≥ 0.1 μF	Power supply by passing	
C102	≥ 0.1 μF	Power supply by passing	
C103	—	Oscillation for start-up	6
C104	0.22 μF	for booster	
C105	2.2 μF	for booster	
C106	—	Delay for POR	8
C109	≥ 0.1 μF	Power supply by passing	
C110, C111	0.33 μF	Phase compensation	
Qret	—	Retract Driver	12
D1	—	Protection for Qret	12
D2	TBD	Protection for parasitic phenomena	

Notes: 1. Output maximum current on spindle motor driver I_{spnmax} is determined by following equation.

$$I_{spnmax} = \frac{R1b}{R1a + R1b} \cdot \frac{V_{R1}}{R_{NF}} \quad [A] \quad (1)$$

where, V_{R1} : Reference Voltage on Pin 24 [V] (= 1.3)

2. Input clock frequency f_{clk} on pin 42 is determined by following equation.

$$f_{clk} = \frac{4}{5} \cdot N_o \cdot P \cdot D1 \cdot (CNT - 0.5) \quad [Hz] \quad (2)$$

where, N_o : Standard rotation speed [rpm]

P: Number of pole

D1: Dividing ratio on divider 1

D1 = 1/12 (when Pin 40 = Open) for 8 pole motor
 = 1/18 (when Pin 40 = Low) for 12 pole motor

CNT: Count number on speed discriminator

CNT = 2605 (when Pin 41 = High)
 = 2084 (when Pin 41 = Open)
 = 1736 (when Pin 41 = Low)

3. Integral constants R2, C1 and C2 can be designed as follows.

$$\omega_O = \frac{1}{10} \cdot 2 \cdot \pi \cdot \frac{N_O}{60} \quad [\text{rad/s}] \quad (3)$$

$$R2 = \frac{1}{9.55} \cdot \frac{R_{nf} \cdot J \cdot \omega_O \cdot N_O \cdot (R1a + R1b)}{V_{R1} \cdot K_T \cdot G_{ctl}} \quad [\Omega] \quad (4)$$

$$C1 = \frac{1}{\sqrt{10} \cdot \omega_O \cdot R2} \quad [F] \quad (5)$$

$$C2 = 10 \cdot C1 \quad [F] \quad (6)$$

where, J: Moment of inertia [kg·cm·s²]

K_T: Torque constant [kg·cm/A]

G_{ctl}: Current control amp gain from pin 22 to pin 17 (= 0.5)

4. It is notice that rotation speed error Nerror is caused by leak current I_{cer2} on pin 22 and this error depend on R1a and R1b as following equation.

$$Nerror = I_{cer2} \cdot \frac{(R1a + R1b)}{VR1} \cdot 100 \quad [\%] \quad (7)$$

where, I_{cer2}: leak current on pin 22 [A]

5. Oscillation period t_{COMM} on pin 39 which period determine the start up characteristics, is should be chosen as following equation.

$$t_{COMM} = \frac{1}{8} \cdot \sqrt{\frac{J}{P \cdot K_T \cdot I_{spnmax}}} \quad \text{to} \quad \frac{1}{4} \cdot \sqrt{\frac{J}{P \cdot K_T \cdot I_{spnmax}}} \quad [s] \quad (8)$$

6. The capacitor C103 on pin 39 can be determined by t_{COMM} and following equation.

$$C103 = \frac{1}{4} \cdot \frac{VR1}{R1a + R1b} \cdot \frac{t_{COMM}}{V_{thH} - V_{thL}} \quad [F] \quad (9)$$

where, V_{thH}: Threshold voltage on start up circuit [V] (= 2.0)

V_{thL}: Threshold voltage on start up circuit [V] (= 0.5)

7. LVI operatig voltage Vsd1, Vsd2 and its hysteresis voltage V_{hys1}, V_{hys2} can be determined by following equations.

for V_{SS}

$$Vsd1 = \left(1 + \frac{R101}{R102}\right) \cdot Vth4 \quad [V] \quad (10)$$

$$Vhys1 = \left(1 + \frac{R101}{R102}\right) \cdot Vhyspm \quad [V] \quad (11)$$

for Vps

$$Vsd2 = \left(1 + \frac{R103}{R104}\right) \cdot Vth3 \quad [V] \quad (12)$$

$$Vhys2 = \left(1 + \frac{R103}{R104}\right) \cdot Vhyspm \quad [V] \quad (13)$$

where, Vth3, Vth4: Threshold voltage on pin 37 and pin 76 [V] (= 1.39)

Vhyspm: Hysteresis voltage on pin 37 and pin 76 [mV] (= 40)

Shut down voltage Vsd1, Vsd2 can be designed by the following range.

Vsd1 ≥ 4.25 [V], Vsd2 ≥ 10 [V]

8. The delay time t_{DLY} of POR for power on reset is determined as follows.

$$t_{DLY} = \frac{C106 \cdot Vth5}{I_{CH3}} \quad [s] \quad (14)$$

where, Vth4: Threshold voltage on pin 38 [V] (= 1.4)

I_{CH3} : Charge current on pin 38 [μA] (= 10)

9. The differential voltage ($V_{ctl} - V_{REF1}$) using for control of VCM driver depend on PWMDAC inputs LSB, MSB as follows.

$$V_{ctl} - V_{REF1} = 2 \cdot V_{REF1} \cdot \frac{D_{PWM} - 50}{100} \cdot \frac{R6}{R5} \cdot H_{FLT}(s) \quad (15)$$

where, D_{PWM} : Duty cycle on PWMIN [%]

$H_{FLT}(s)$: Transfer function from pin 62 (PWMOUT) to pin 64 (V_{ctl}) as shown in equation (17)

To be satisfied with above equation (15), it is notice that the ratio of R6 to R7 must be chosen as shown below.

$$\frac{R8}{R7} = 2 \cdot \frac{R6}{R5} \cdot \frac{1}{1 - \frac{R6}{R5}} \quad (16)$$

$H_{FLT}(s)$

$$= \frac{1}{\left[\begin{aligned} &1 + s \cdot \left[C5 \cdot R// - C3 \cdot (R// + R3) \cdot \frac{R6}{R5} + C4 \cdot (R// + R3 + R4) \right] \\ &+ s^2 \cdot \left[C5 \cdot C4 \cdot R// \cdot (R3 + R4) - C5 \cdot C3 \cdot R// \cdot R3 \cdot \frac{R6}{R5} + C3 \cdot C4 \cdot R4 \cdot (R// + R3) \right] \\ &+ s^3 \cdot C3 \cdot C4 \cdot C5 \cdot R// \cdot R3 \cdot R4 \end{aligned} \right]} \quad (17)$$

where, $R// = \frac{R7 \cdot R8}{R7 + R8}$ (18)

If you choose the $R// \ll R3$, then equation (17) can be simplified as following equation.

$$H_{FLT}(s) = \frac{1}{1 + \frac{s}{\omega_O}} \cdot \frac{1}{1 + 2 \cdot \zeta \cdot \left(\frac{s}{\omega_n}\right) + \left(\frac{s}{\omega_n}\right)^2} \quad (19)$$

where,

$$\omega_0 = \frac{1}{C5 \cdot R//} \quad (20)$$

$$\omega_n = \frac{1}{\sqrt{C3 \cdot C4 \cdot R3 \cdot R4}} \quad (21)$$

$$\zeta = \frac{C4 \cdot (R3 + R4) - C3 \cdot R3 \cdot \frac{R6}{R5}}{2 \cdot \sqrt{C3 \cdot C4 \cdot R3 \cdot R4}} \quad (22)$$

10. The relationship between the output current I_{vcm} and the input voltage ($V_{ctl} - V_{REF1}$) on VCM driver is as follows.

$$I_{vcm}(s) = (V_{ctl} - V_{REF1}) \cdot K_{vcm} \cdot \frac{1}{R_s} \cdot H_{vcm}(s) \quad (23)$$

where, V_{ctl} : Input control voltage for VCM driver on pin 64 [V]

V_{REF1} : Reference voltage on pin 61 [V] (= 4.6)

K_{vcm} : DC gain of VCM driver
 (= 1.82 for High gain mode)
 (= 0.45 for Low gain mode)

$H_{vcm}(s)$: Transfer function of VCM driver as shown following equation

$$H_{vcm}(s) = \frac{1}{1 + 2 \cdot \zeta_{VCM} \cdot \left(\frac{s}{\omega_{VCM}}\right) + \left(\frac{s}{\omega_{VCM}}\right)^2} \quad (24)$$

where,

$$\omega_{VCM} = \sqrt{\omega_p \cdot \frac{R_s}{L_m}} \quad (25)$$

$$\zeta_{VCM} = \frac{1}{2} \cdot \left(1 + \frac{R_L}{R_s}\right) \cdot \sqrt{\frac{1}{\omega_p} \cdot \frac{R_s}{L_m}} \quad (26)$$

where, ω_p : Bandwidth of internal power amplifiers for VCM driver [rad/s]
 (= $3 \cdot \pi \cdot 10^6$)

L_m : Inductance of the VCM coil [H]

R_L : Resistance of the VCM coil [Ω]

and from above equations the -3 dB bandwidth f_{VCMC} of VCM driver is as following equation.

$$f_{VCMC} = \frac{\omega_{VCM}}{2 \cdot \pi} \cdot \sqrt{\left[1 - 2 \cdot \zeta_{VCM}^2\right] + \sqrt{\left[2 \cdot \zeta_{VCM}^2 - 1\right]^2 + 1}} \quad (27)$$

11. The frequency response of VCM driver maybe have a gain peaking because of the resonance of the motor coil impedance. If you want to tune up for this characteristics, you can reduce the peaking by additional snubber circuit R_x and C_x as follows.

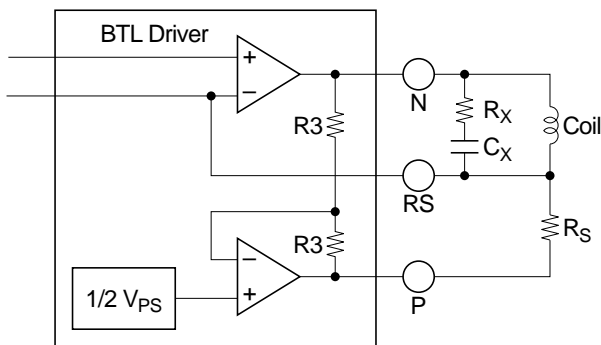
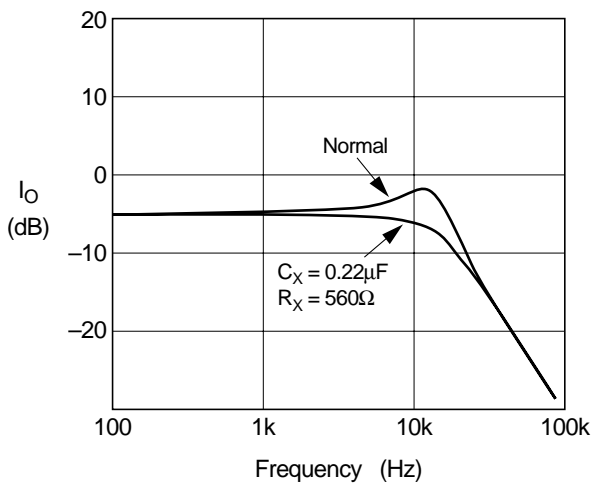

Figure 1 VCM Driver Block Diagram



(for example) $R_L = 14.7 \Omega$, $R_S = 1 \Omega$, $L = 1.7 \text{ mH}$, $\text{Gain} = L$

12. The retract current I_{ret} is determined by following equation.

$$I_{ret} = \frac{V_{retpow} - V_{sat}(Q_{ret}) - V_F(D1) - V_{sat_{VL}}}{R_{108} + R_S + R_L} \quad (28)$$

where, V_{retpow} : Applied voltage on pin 78 [V]

$V_{sat}(Q_{ret})$: Saturation voltage of Q_{ret} [V]

$V_F(D1)$: Forward voltage of D1 [V]

Absolute Maximum Ratings (Ta = 25°C)

Item	Symbol	Rating	Unit	Notes
Power supply voltage	Vps	+15	V	1
Signal supply voltage	V _{SS}	+7	V	2
Input voltage	V _{IN}	V _{SS}	V	3
Output current-Spindle	I _{ospn} (Peak)	1.8	A	
	I _{ospn} (DC)	1.2	A	
Output current-VCM	I _{ovcm} (Peak)	1.2	A	
	I _{ovcm} (DC)	0.8	A	
Power dissipation	P _T	5	W	
Junction temperature	T _J	+150	°C	
Storage temperature	T _{stg}	-55 to +125	°C	

Notes: 1. Operating voltage range is 10.2 V to 13.8 V.

2. Operating voltage range is 4.25 V to 5.75 V

3. Applied to Pin 40, 41, 42, 44, 56, 57 and pin 62

4. Operating junction temperature range is T_{jop} = 0°C to +125°C

5. ASO of upper and lower power transistor are shown below.

Operating locus must be within the ASO.

6. The OTSD (Over Temperature Shut Down) function is built in this IC to avoid same damages by over heat of this chip. However, please note that if the junction temperature of this IC becomes higher than the operating maximum junction temperature (T_{jopmax} = 125°C), the reliability of this IC often goes down.

7. Thermal resistance: $\theta_{j-a} \leq 35^\circ\text{C/W}$ with 6 layer multi glass-epoxy board.

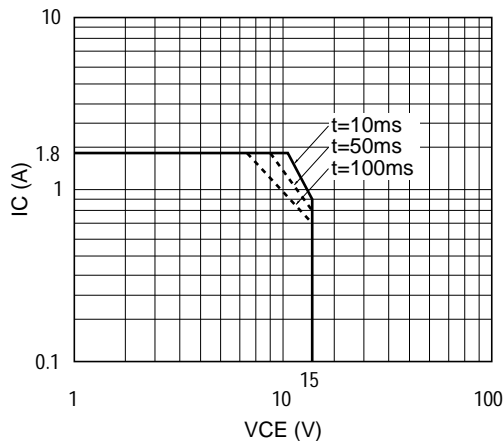

Figure 2 ASO of Output Stages (Spindle)

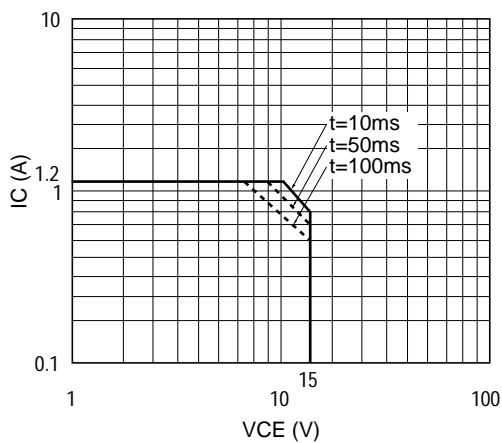

Figure 3 ASO of Output Stages (VCM)

Electrical Characteristics (Ta = 25°C, Vps = 12 V, VSS = 5 V)

Item		Symbol	Min	Typ	Max	Unit	Test Conditions	Applicable Pins	Note
Supply current	for V _{SS}	I _{SS0}	—	5.8	7.0	mA	SPNENAB = Open VCMENAB = L	36	
		I _{SS1}	—	21	27	mA	SPNENAB = H VCMENAB = H	36	
	for V _{ps}	I _{ps0}	—	1.7	2.2	mA	SPNENAB = Open VCMENAB = L	25, 77	
		I _{ps1}	—	19	24	mA	SPNENAB = H VCMENAB = H	25, 77	
Logic input 1 (GAIN) (RESINH)	Input low voltage	V _{IL1}	—	—	0.8	V		57, 62	
	Input high voltage	V _{IH1}	2.0	—	—	V			
	Input low current	I _{IL1}	—	—	±10	μA	Input = GND		
	Input high current	I _{IH1}	—	—	±10	μA	Input = 5.0 V		
Logic input 2 (CLOCK)	Input low voltage	V _{IL2}	—	—	0.8	V		42	
	Input high voltage	V _{IH2}	3.5	—	—	V			
	Input low current	I _{IL2}	—	-180	-260	μA	Input = GND		
	Input high current	I _{IH2}	—	230	330	μA	Input = 5.0 V		
Logic input 3 (VCMENAB)	Input low voltage	V _{IL3}	—	—	0.8	V		56, 59	
	Input high voltage	V _{IH3}	2.0	—	—	V			
	Input low current	I _{IL3}	—	—	±10	μA	Input = GND		
	Input high current	I _{IH3}	—	—	330	μA	Input = 5.0 V		
Logic input 4 (SPNENB)	Input low voltage	V _{IL4}	—	—	1.0	V		44	
	Input middle voltage	V _{IM4}	2.0	—	3.1	V			
	Input high voltage	V _{IH4}	3.9	—	—	V			
	Input low current	I _{IL4}	-75	-105	-150	μA	Input = GND		
	Input high current	I _{IH4}	75	105	150	μA	Input = 5.0 V		

Electrical Characteristics (Ta = 25°C, Vps = 12 V, Vss = 5 V) (cont)

Item	Symbol	Min	Typ	Max	Unit	Test Conditions	Applicable Pins	Note
Logic input 4 (SPNENB)	Input dead current I_{DEAD}	—	—	± 10	μA		44	
Logic input 5 (POLSEL) (CONTSEL)	Input low voltage V_{IL5}	—	—	1.0	V		40, 41	
	Input middle voltage V_{IM5}	2.0	—	3.1	V			
	Input high voltage V_{IH5}	3.9	—	—	V			
	Input low current I_{IL5}	-38	-53	-75	μA	Input = GND		
	Input high current I_{IH5}	38	53	75	μA	Input = 5.0 V		
Spindle driver	Total saturation voltage V_{satspn}	—	0.8	1.1	V	$I_{spn} = 1.0 A$	16, 20, 21	
		—	—	0.5	V	$I_{spn} = 0.35 A$		
	Saturation at braking V_{break}	—	—	0.7	V	$I_{break} = 0.6 A$		
	Leak current I_{cer1}	—	—	± 2.0	mA	SPNENAB = Open		
	Current limiter reference voltage V_{OCL}	430	480	530	mV	$V_{CLREF} = 500 mV$ $R_{NF} = 1.0 \Omega$	17	
	Control amp gain G_{ctl}	—	-2	± 2	dB	$R_{NF} = 1.0 \Omega$	17, 22	
B-EMF amp.	Input sensitivity V_{min}	—	100	—	mVp-p		16, 20, 21	1
Charge pump	Reference voltage V_{R1}	1.06	1.17	1.28	V	$R1a + R1b = 24 \Omega$ $C-PUMP = 1.0 V$	22, 24	
	Charge current I_{CH1}	40	45	50	μA			
	Discharge current I_{DIS1}	-40	-45	-50	μA			
	Leak current I_{cer2}	—	—	± 50	nA			
Speed discri	Operating frequency f_{clk}	—	—	8.0	MHz		42	
Start up circuit	Threshold voltage V_{thH}	1.6	1.8	2.0	V		24, 39	
		V_{thL}	0.3	0.5	0.7	V		
	Charge current I_{CH2}	21	23	26	μA	$R1a + R1b = 24 k\Omega$ $COMM = 1 V$		
	Discharge current I_{DIS2}	-19	-22	-25	μA			

Electrical Characteristics (Ta = 25°C, Vps = 12 V, Vss = 5 V) (cont)

Item	Symbol	Min	Typ	Max	Unit	Test Conditions	Applicable Pins	Note
READY	Output high voltage	Vohr	V _{ss} - 0.4	—	V _{ss}	V	I _o = -1 mA	43
	Output low voltage	Volr	—	—	0.4	V	I _o = 1 mA	
VCM driver	Total saturation voltage	Vsatvcm	—	0.8	1.1	V	Ivcm = 0.8 A	2, 3
		—	0.4	0.55	V	Ivcm = 0.4 A		
	Output leak current	Icer3	—	—	±2	mA	Vce = 15 V	
	Total output offset voltage	Voff(H)	—	—	±20	mV	V _{CTL} = OP (-) V _{REF} = OP (+)	2, 80
		Voff(L)	—	—	±10	mV		
	Output quiescent voltage	Vqvcm	5.6	6.0	6.4	V	R _L = 10 Ω R _S = 1.0 Ω	2, 3
	Total Gain Bandwidth	B	—	26	—	kHz	R _S = 1.0 Ω, R _L = 28 Ω	2, 3
—			50	—	kHz	R _S = 1.0 Ω, R _L = 14 Ω		
Transfer gain	gm (H)	—	1.74	±5%	A/V	Higain-mode R _S = 1.0 Ω, R _L = 14 Ω	2, 64, 80	
	gm (L)	—	0.44	±5%	A/V	Logain-mode R _S = 1.0 Ω, R _L = 14 Ω		
Retract driver	Retpow voltage	Vretpow	0.8	—	—	V	Ireton = 0.1 mA	78
	Retout sink current	Ireton	5	8	—	mA	Vretpow = 4.0 V	
	Output leak current	Icer4	—	—	±10	μA	Vreton = 15 V, Vretpow = 15 V	79
	Low side saturation voltage	VsatVL	0.1	0.23	0.35	V	Iret = 0.1 A	3
OP Amp	Input current	linop	—	—	±500	nA		63, 65
	Input offset voltage	Vosop	—	—	(±7)	mV		1
	Common mode input voltage range	Vcmop	0	—	Vps - 0.2	V		
	Output high voltage	Vohop	Vps - 1.3	—	—	V	Iout = 1.0 mA	64

Electrical Characteristics (Ta = 25°C, Vps = 12 V, Vss = 5 V) (cont)

Item		Symbol	Min	Typ	Max	Unit	Test Conditions	Applicable Pins	Note
OP Amp	Output low voltage	Volop	—	—	1.1	V	Iout = 1.0 mA	64	
Comparator	Input sensitivity	Vmin2	±9	0	—	mV		2, 3, 60	
	Output low voltage	Volcp	—	—	0.4	V	I _o = 1 mA	60	
	Output high voltage	Vohcp	V _{SS} - 1.8	—	V _{SS}	V	I _o = 1 mA		
Vref1	Output voltage	Vref1	—	4.6	±3%	V	I _o = 20 mA	61	
	Output resistance	Ro1	—	—	5.0	Ω	I _o = 20 mA		
Power monitor	Threshold voltage	Vth3	—	1.39	+3% -2%	V	V _{SS} = 5 V	76	2
	Hysteresis	Vhyspm 1	25	40	55	mV	V _{SS} = 5 V		
	Threshold voltage	Vth4	—	1.38	+3% -2%	V	V _{SS} = 4 V	37	2
	Hysteresis	Vhyspm 2	25	40	55	mV	V _{SS} = 4 V		
POR	Output low voltage	V _{OL2}	—	—	0.4	V	I _o = 1 mA	45	
		V _{OL3}	—	—	0.4	V	I _o = 1 mA V _{SS} = Vps = 1.0 V		
	Output leak current	Icer5	—	—	±10	μA	Vpor = 7 V		
	Threshold voltage	Vth5	—	1.4	±5%	V		38	
	Charge current	I _{CH3}	—	12	±25%	μA			
	Discharge current	I _{DIS3}	10	—	—	mA			
OTSD	Operating temperature	Tsd	125	150	—	°C			1
	Hysteresis	Thys	—	25	—	°C			1

Notes: 1. Design guide only.

2. Variations of threshold voltage Vth3 and Vth4 depending on the power supply V_{SS} are shown in Figure.4.

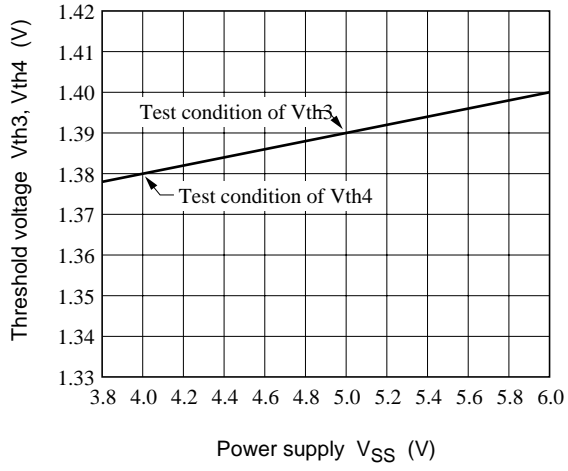
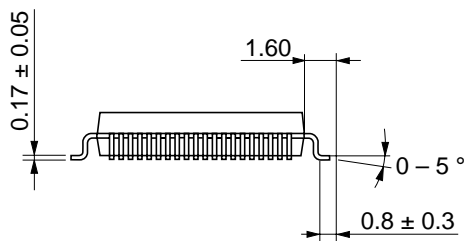
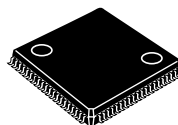
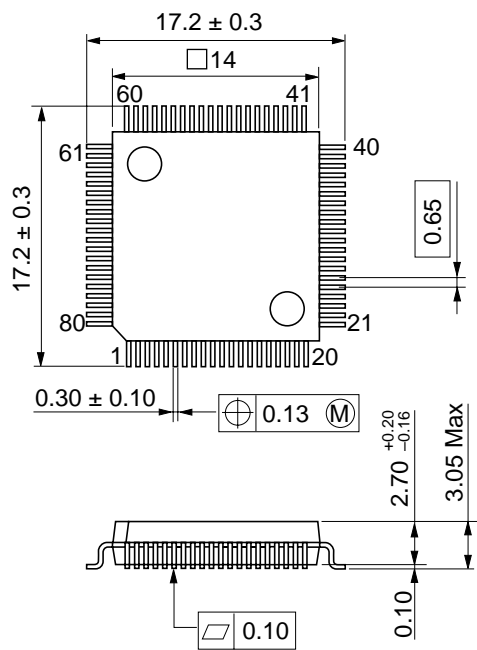

Figure 4

Package Dimensions

Unit: mm



Hitachi code	FP-80E
EIAJ code	—
JEDEC code	—

Cautions

1. Hitachi neither warrants nor grants licenses of any rights of Hitachi's or any third party's patent, copyright, trademark, or other intellectual property rights for information contained in this document. Hitachi bears no responsibility for problems that may arise with third party's rights, including intellectual property rights, in connection with use of the information contained in this document.
2. Products and product specifications may be subject to change without notice. Confirm that you have received the latest product standards or specifications before final design, purchase or use.
3. Hitachi makes every attempt to ensure that its products are of high quality and reliability. However, contact Hitachi's sales office before using the product in an application that demands especially high quality and reliability or where its failure or malfunction may directly threaten human life or cause risk of bodily injury, such as aerospace, aeronautics, nuclear power, combustion control, transportation, traffic, safety equipment or medical equipment for life support.
4. Design your application so that the product is used within the ranges guaranteed by Hitachi particularly for maximum rating, operating supply voltage range, heat radiation characteristics, installation conditions and other characteristics. Hitachi bears no responsibility for failure or damage when used beyond the guaranteed ranges. Even within the guaranteed ranges, consider normally foreseeable failure rates or failure modes in semiconductor devices and employ systemic measures such as fail-safes, so that the equipment incorporating Hitachi product does not cause bodily injury, fire or other consequential damage due to operation of the Hitachi product.
5. This product is not designed to be radiation resistant.
6. No one is permitted to reproduce or duplicate, in any form, the whole or part of this document without written approval from Hitachi.
7. Contact Hitachi's sales office for any questions regarding this document or Hitachi semiconductor products.

HITACHI

Hitachi, Ltd.

Semiconductor & Integrated Circuits.
Nippon Bldg., 2-6-2, Ohte-machi, Chiyoda-ku, Tokyo 100-0004, Japan
Tel: Tokyo (03) 3270-2111 Fax: (03) 3270-5109

URL North America : <http://semiconductor.hitachi.com/>
 Europe : <http://www.hitachi-eu.com/hel/ecg>
 Asia (Singapore) : <http://www.has.hitachi.com.sg/grp3/sicd/index.htm>
 Asia (Taiwan) : http://www.hitachi.com.tw/E/Product/SICD_Frame.htm
 Asia (HongKong) : <http://www.hitachi.com.hk/eng/bo/grp3/index.htm>
 Japan : <http://www.hitachi.co.jp/Sicd/indx.htm>

For further information write to:

Hitachi Semiconductor
(America) Inc.
179 East Tasman Drive,
San Jose, CA 95134
Tel: <1> (408) 433-1990
Fax: <1> (408) 433-0223

Hitachi Europe GmbH
Electronic components Group
Dornacher Straße 3
D-85622 Feldkirchen, Munich
Germany
Tel: <49> (89) 9 9180-0
Fax: <49> (89) 9 29 30 00

Hitachi Europe Ltd.
Electronic Components Group.
Whitebrook Park
Lower Cookham Road
Maidenhead
Berkshire SL6 8YA, United Kingdom
Tel: <44> (1628) 585000
Fax: <44> (1628) 778322

Hitachi Asia Pte. Ltd.
16 Collyer Quay #20-00
Hitachi Tower
Singapore 049318
Tel: 535-2100
Fax: 535-1533

Hitachi Asia Ltd.
Taipei Branch Office
3F, Hung Kuo Building, No.167,
Tun-Hwa North Road, Taipei (105)
Tel: <886> (2) 2718-3666
Fax: <886> (2) 2718-8180

Hitachi Asia (Hong Kong) Ltd.
Group III (Electronic Components)
7/F., North Tower, World Finance Centre,
Harbour City, Canton Road, Tsim Sha Tsui,
Kowloon, Hong Kong
Tel: <852> (2) 735 9218
Fax: <852> (2) 730 0281
Telex: 40815 HITEC HX

Copyright ' Hitachi, Ltd., 1999. All rights reserved. Printed in Japan.

HITACHI